

DRIVE THE CHANGE

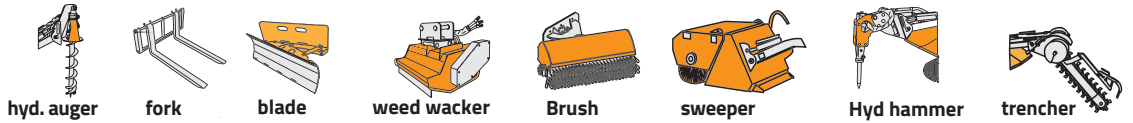

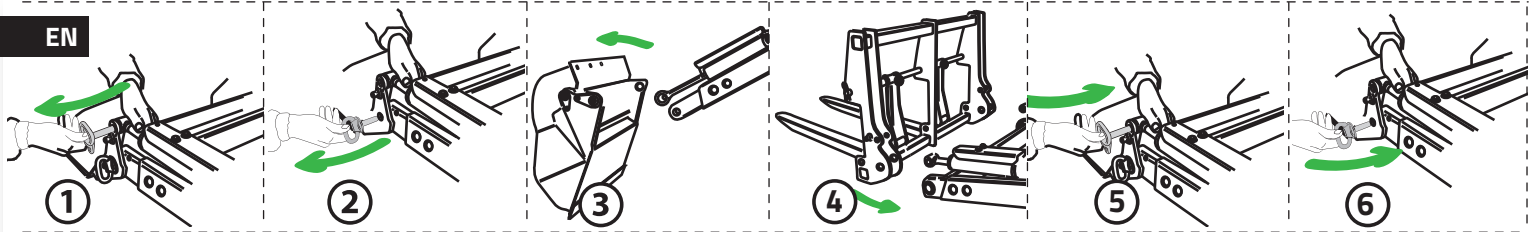

MANUAL QUICK ATTACH

RI



AC-ACW



HI



HIAC-HIACW



AVAILABLE VERSIONS



SPECIFICATIONS

	METRIC	U.S.	10.85	13.85	14.85
ENGINE					
Gas	Honda Gx 390 13 hp			•	
Diesel	Yanmar LN 100 AE 10 hp		•		
	Kubota 14 hp				•
TRANSMISSION					
Type	Hydrostatic		•	•	•
Hydraulic pump	2 variable pistons pumps		•	•	•
TRACKS					
Stand. tracks width	180 mm (7.1 in)		•	•	•
Rocking Rollers	2		•	•	•
HYDRAULIC SYSTEM					
Hydraulic pump	Gear pump		•	•	•
Flow std	1x15,8 l/min (1x4.2 gpm)		•	•	•
Max pressure	150 bar (2180 psi)		•	•	•
PERFORMANCE AND DIMENSIONS					
Max. Travel Speed	(5 Km/h)(3.1 mph)		•		•
	(6 Km/h)(3.7 mph)			•	
Dry Weight	540 to/a 750 kg (1191 to 1654)		•	•	•
Operative weight	800 kg (1762 lb)		•	•	•
Gross capacity	0.28 m ³ (0.37 yd ³) 0.45 m ³ (0.59 yd ³)		•	•	•
Parking brake	Yes		•	•	•

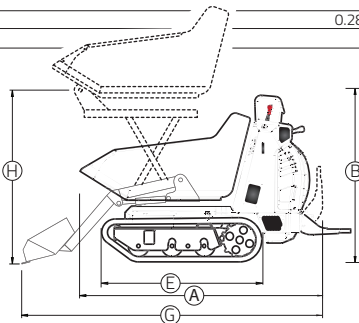
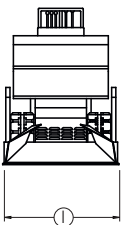

	mm	in
A	1926	75.8
B	1336	52.6
C	739	29.1
D	810	31.9
E	1132	44.6
G	2595	102.2
H	1500	59.1
I	835	32.9

POWERBANK WHEN YOU NEED ENERGY + **HWT GREEN VEHICLE** ELECTRIC VERSION

REMOTE CONTROL

SOME BENEFITS