



ENGINE

| | |
|-------------------------------|--|
| Model | FPT F5BFL413C |
| Emissions Certification | Tier 4 Final |
| Type | Diesel 4-stroke, Turbocharged |
| Cylinders | 4 |
| Bore/Stroke | 3.90 x 4.33 in (99 x 110 mm) |
| Displacement | 207 in ³ (3.4 L) |
| Fuel injection | Direct, high pressure common rail – HPCR |
| Fuel | Diesel |
| Engine speeds* | RPM |
| Rated speed – full load | 2200 |
| Low idle | 900 – 1000 |
| High idle – no load | 2330 – 2430 |
| Horsepower @ 2200 RPM: | |
| Gross | 90 hp (67 kW) |
| Net w/ viscous fan** | 89 hp (66 kW) |
| Net | 83 hp (62 kW) |
| Maximum torque @ 1400 RPM: | |
| Gross | 306 lb-ft (415 N-m) |
| Net w/ viscous fan | 305 lb-ft (413 N-m) |
| Net | 299 lb-ft (405 N-m) |
| Torque rise at rated speed | 43% +/- 5% |
| Radiator: | |
| Core type | Square wave |
| Core size area | 486 in ² (3 145 cm ²) |
| Rows of tubes | 5 |
| 39° fan: | |
| Style | 7 blade suction |
| Diameter | 19.65 in (499 mm) |
| Ratio | 1.1:1 |
| Pump operating angle ratings: | |
| Side to side | Rated 35° |
| Fore and aft | Rated 35° |
| Oil filtration | Replaceable, full flow spin on |

NOTE: *Meets federal emission regulations.

**Viscous fan included w/ Cab
Convenience package.

DRIVETRAIN

Transmission – standard:
4F-4R Power Shuttle Synchronesh
Transmission manual gear shift,
fully synchronized

Transmission – optional:
Powershift S-Type, 4F-3R fully synchronized

Specifications below apply to both Power Shuttle
and Powershift S-Type transmission unless
otherwise indicated.

| Gear ratios | Forward/Reverse | |
|-------------|-----------------|--|
| 1st | 5.603/4.643 | |
| 2nd | 3.481/2.884 | |
| 3rd | 1.584/1.313 | |
| 4th | 0.793/0.657* | |

| Travel speeds | Forward | Reverse |
|---------------|-------------|--------------|
| | mph (kph) | mph (kph) |
| 1st | 3.8 (6.1) | 4.5 (7.3) |
| 2nd | 6.1 (9.8) | 7.3 (11.7) |
| 3rd | 13.1 (21.1) | 15.7 (25.3) |
| 4th | 24.6 (39.6) | 29.4 (47.3)* |

| | |
|------------------------|-------------------------------------|
| Torque converter ratio | 3.2 |
| Differential-lock | On-the-go push-button activation |

| | |
|-----------------------|-----------|
| Front 4WD/Rear axle: | |
| Differential ratio | 2.0/2.5 |
| Planetary hub ratio | 6.0/6.4 |
| Total reduction ratio | 12.0/16.0 |

| | |
|--|--|
| Service brakes: | |
| Individually applied, power assisted, hydraulically actuated, maintenance-free, self-adjusting, outboard mounted, wet disc, 2 per side. | |
| Total disc area | 384 in ² (0.25 m ²) |

| | |
|----------------|--|
| Parking brakes | Trans Mounted spring-applied hydraulic release – SAHR |
|----------------|--|

NOTE: *4R not available on Powershift S-Type.
Travel speeds at 2293 engine
RPM specified: w/ 19.5 L x 24.0 tires.
Speeds decrease w/ 17.5 L x 24.0 rear tires.

ELECTRICAL

| | |
|--------------------|---------------------------|
| Voltage | 12 Volts, negative ground |
| Alternator | 160 amp |
| Battery | 850 cold-cranking amps |
| Opt. batteries – 2 | 850 cold-cranking amps |
| Power plugs – 2 | 30 amps total |

OPERATOR ENVIRONMENT

ROPS/FOPS certified protective canopy;
Anti-vandalism cover for dash – w/ canopy only;
Rear fenders extensions; Coat hook w/ garment
strap; Interior rearview mirror, convex
3.54 in (90 mm) wide x 10.83 in (275 mm) high;
Non-suspension seat – 180° swivel – Vinyl; 2 in
(50 mm) retractable seat belt; Cup holder/storage
tray mounted on left-hand fender; Right-hand
storage compartment w/ lid.

Gauges:
Engine water temperature; Converter oil
temperature; Fuel level; Tachometer/
hourmeter; DEF Level.

Warning lights:
Air cleaner restriction; Alternator; A/C high
pressure; Cold start; Engine oil pressure
low; Hydraulic oil filter bypass; Parking brake
engagement; Low fuel; Water in fuel; Low DEF.

Audible alarms:
Coolant temperature; Engine oil pressure;
Parking brake engagement; Shuttle
engagement/seat position; Backup,
Converter temperature; Low DEF.

Horn Dual switched front and rear

OPERATING WEIGHT

Configuration 1 – SAE Transport:
Standard dipper, 82 in (2.08 m) LL bucket,
2WD, 19.5 L – 24 rear tires, 24 in HD backhoe
bucket, flip over stabilizer pads, 1 Door Cab
w/ Heat and A/C, Cloth Mechanical Suspension
seat, Small front counter weight, S-type
powershift transmission, no operator,
fully fueled.
16,589 lb (7 525 kg)

Configuration 2 – SAE Transport:
No Operator, 1 Door Cab, 4WD, AC, E-hoe,
SPS Shift, Wobble Stick Mechanical BH
Controls, Front Counterweight 4 Speed Manual
Transmission, Boom Guard, Extendahoe®, 82 in
GP Loader Bucket Galaxy 12-16.5 @ 49 psi
Front Tires, Solideal 19.5 L – 24 @ 29 psi
Rear Tires.
17,751 lb (8 052 kg)

Add-on weights:

| | |
|----------------------------|-----------------|
| Cab-over canopy | 309 lb (140 kg) |
| Fabricated stabilizer pads | 141 lb (64 kg) |
| Counterweights | 700 lb (318 kg) |
| Extendahoe® | 285 lb (129 kg) |
| 4WD w/ driveshaft guard | 283 lb (128 kg) |

HYDRAULICS

| | |
|--|---|
| Pump: | |
| Parker P330 Single Section Gear Pump | |
| Main relief pressure: | |
| Standard | 3,350 +/- 50 psi (231 +/- 3.5 bar) |
| Filtration: | |
| 7-micron, return line, full flow, spin on element, condition indicator light for filter. | |
| Oil cooler | Heavy-duty |
| Loader flow @ rated engine RPM: | |
| | 28.5 gpm @ 3,350 psi (108.0 L/min @ 231 bar) |

Loader control valve:
Two or three-spool open center monoblock valve. Two and three-spool valves have a single lever manual control for lift and tilt functions. Three-spool valve uses a proportional Electro-Hydraulic control for the auxiliary function. The lift lever has a positive hold "Float" position and a "return-to-dig" feature. System Main Relief valve is single stage w/ Manual Backhoe Controls, dual stage relief valve w/ Pilot Backhoe Controls.

Loader auxiliary hydraulics w/ proportional thumb switch w/ detent on loader control handle.

Loader auxiliary hydraulics w/ full available flow:
0 – 28.5 gpm (0 – 108 L/min)

Backhoe flow @ rated engine RPM:
28.5 gpm @ 3,350 psi
(108 L/min @ 231 bar)

Manual backhoe control valve:
Six or seven-spool monoblock open center control valve. Features "Pro-Control" which includes custom designed spools for each individual function along w/ "swing cushioning" valve for zero-wag swing control. Basic control valve has an open center parallel circuit for all functions.

Pilot backhoe control valve:
Six, seven or eight-spool sectional closed center control valve. Features "Pro-Control" which includes custom designed spools for each individual function along w/ "swing cushioning" valve for zero-wag swing control. Basic control valve is closed center, w/ circuits in parallel w/ a post-compensated, flow sharing feature for simultaneous operation of all circuits.

Unidirectional auxiliary hydraulics:
Unidirectional hydraulic valve is equipped w/ an adjustable LS relief valve to control attachment pressure and a 6 position flow control selector for 6 detented, distinct flow settings.

Actuation:
Manual backhoe controls – cab floor pedal
Pilot controls – left-hand joystick

Bidirectional auxiliary hydraulics*:
Actuation:
Activate the bidirectional Switch located on the rear console
Manual shift – bidirectional linkage on far right of backhoe tower
Pilot controls – left-hand joystick.

NOTE: *Available w/ Combo Aux. Hyd. option.

SERVICE CAPACITIES

| | |
|-------------------------------------|--------------------|
| Fuel tank | 35.0 gal (132.0 L) |
| DEF tank | 3.6 gal (13.5 L) |
| Hydraulic system: | |
| Total | 111 qt (105.0 L) |
| w/ Extendahoe® | 117 qt (110.7 L) |
| Reservoir w/ filter | 55 qt (52.4 L) |
| Reservoir w/o filter | 53 qt (50.5 L) |
| Transmission – total system: | |
| 2WD Standard | 18 qt (17.0 L) |
| 2WD Powershift | 23 qt (21.7 L) |
| 4WD Standard | 21 qt (19.4 L) |
| 4WD Powershift | 22 qt (20.7 L) |

| | |
|------------------------------|------------------|
| Front axle: | |
| 4WD Differential | 8.1 qt (7.7 L) |
| 4WD Planetaries – each | 0.5 qt (0.5 L) |
| Rear axle: | |
| Differential and planetaries | 14.4 qt (13.6 L) |
| Engine oil w/ filter | 8.5 qt (8.0 L) |
| Cooling system: | |
| w/ heater | 19.0 qt (18.0 L) |
| w/o heater | 18.3 qt (17.3 L) |
| Window washer reservoir | 3.0 qt (2.8 L) |

OTHER SPECIFICATIONS

| | |
|---------------------|------------------------------|
| Front tires: | |
| 2WD | 11.0 L x 16.0, 10-ply rating |
| 4WD | 12.0 L x 16.5, 8-ply rating |
| Rear tires: | |
| 2/4WD | 19.5 L x 24.0, 10-ply rating |
| 2/4WD | 17.5 L x 24.0, 10-ply rating |

Loader:
Bucket position indicator; Lifting lugs on standard bucket; Single lever control w/ self-leveling and return-to-dig; Hand operated clutch disconnects on loader and shift levers, single lever 4-function loader control: lift, dump, clutch cut-out, differential lock.

Turning radius*: Curb to Curb

| | |
|--------------------------|----------------------|
| 2WD: | |
| Brakes on | 10 ft 8 in (3.24 m) |
| Brakes off | 12 ft 4 in (3.76 m) |
| 4WD – engaged: | |
| Brakes on | 11 ft 4 in (3.45 m) |
| Brakes off | 13 ft 10 in (4.21 m) |
| 4WD – disengaged: | |
| Brakes on | 11 ft 0 in (3.36 m) |
| Brakes off | 12 ft 3 in (3.72 m) |

Backhoe:
Over center design, Fabricated "S" boom;
Open-center hydraulics – Pro Control System.

NOTE: *Turning radius dimensions curb to curb w/ 17.5 L x 24.0 rear tires.

LOADER BUCKET SIZES

| Type | Width | Weight | Struck | Heaped Capacity |
|--------------------------------------|----------------|--------------------|---|---|
| Long Lip Bucket without bolt-on edge | 82 in (2.08 m) | 683 lb (310 kg) | 0.88 yd ³ (0.67 m ³) | 1.03 yd ³ (0.79 m ³) |
| | 93 in (2.36 m) | 1,188 lb* (539 kg) | 1.10 yd ³ (0.84 m ³) | 1.29 yd ³ (0.99 m ³) |
| 4 IN 1® Bucket with bolt-on edge | 82 in (2.08 m) | 1,572 lb* (713 kg) | 0.85 yd ³ (0.65 m ³) | 1.05 yd ³ (0.80 m ³) |

NOTE: *Weight of 4 IN 1® bucket includes edges, cylinders and tube lines.

BACKHOE BUCKET SIZES

| Type | Width | Weight | Heaped Capacity |
|-----------------------------------|----------------|-----------------|--|
| General Purpose Trenching Buckets | 18 in (457 mm) | 232 lb (105 kg) | 4.70 ft ³ (0.13 m ³) |
| | 24 in (610 mm) | 272 lb (123 kg) | 6.26 ft ³ (0.18 m ³) |
| Universal Buckets | 12 in (305 mm) | 295 lb (137 kg) | 3.40 ft ³ (0.10 m ³) |
| | 18 in (457 mm) | 356 lb (162 kg) | 5.30 ft ³ (0.15 m ³) |
| | 24 in (610 mm) | 427 lb (194 kg) | 7.70 ft ³ (0.22 m ³) |
| | 30 in (762 mm) | 489 lb (222 kg) | 10.20 ft ³ (0.29 m ³) |
| | 36 in (914 mm) | 552 lb (251 kg) | 12.70 ft ³ (0.36 m ³) |
| High Capacity Buckets | 24 in (610 mm) | 447 lb (203 kg) | 8.50 ft ³ (0.24 m ³) |

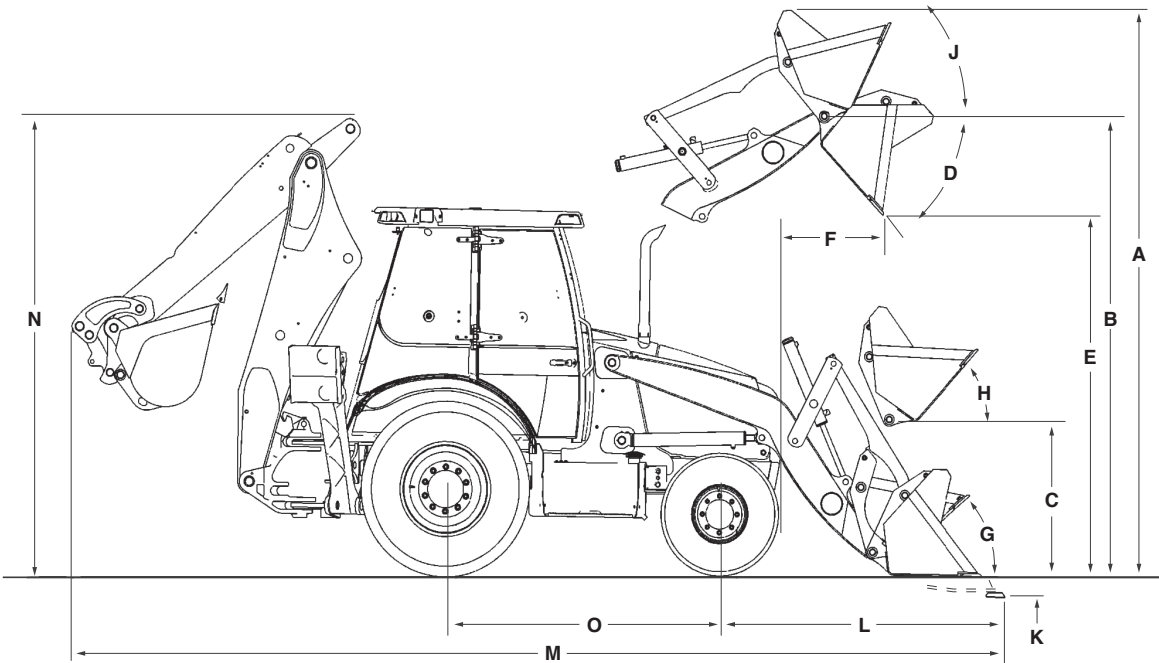

Line drawings are for illustrative purpose only and may not be exact representation of unit.

LOADER DIMENSIONS

| | Long Lip Bucket | 4 IN 1® Bucket |
|---|-----------------------|-----------------------|
| A. Overall operating height – fully raised | 13 ft 9 in (4.18 m) | 13 ft 8 in (4.16 m) |
| Height to: | | |
| B. Bucket hinge pin fully raised | 11 ft 3 in (3.42 m) | 11 ft 3 in (3.42 m) |
| C. Bucket hinge pin at SAE carry | 13.6 in (345 mm) | 13.6 in (345 mm) |
| D. Dump angle at full height | 47° | 47° |
| E. Dump clearance at full height, 45° dump: | | |
| Bucket | 8 ft 10 in (2.69 m) | 8 ft 11 in (2.71 m) |
| Clam open | – | 9 ft 8 in (2.96 m) |
| F. Dump reach at full height, 45° dump: | | |
| Bucket | 31.5 in (801 mm) | 29.1 in (738 mm) |
| Clam open | – | 15.3 in (388 mm) |
| Bucket rollback: | | |
| G. @ Groundline | 42° | 42° |
| H. @ SAE carry | 42° | 42° |
| J. @ Full height | Adjustable | Adjustable |
| K. Digging depth below grade: | | |
| Bucket flat | 6.1 in (155 mm) | 4.8 in (122 mm) |
| Clam open – dozing | – | 4.1 in (103 mm) |
| L. Reach from front axle centerline – bucket on ground | 6 ft 10 in (2.08 m) | 6 ft 10 in (2.03 m) |
| Lift capacity to full height | 6,803 lb (3 086 kg) | 6,459 lb (2 930 kg) |
| Breakout force: | | |
| Lift cylinders | 9,506 lb (4 228 daN) | 9,276 lb (4 126 daN) |
| Dump cylinders | 10,622 lb (4 724 daN) | 11,312 lb (5 032 daN) |
| Bucket cutting edge width | 82.5 in (2.09 m) | 82.0 in (2.08 m) |
| Maximum grading angle | 114° | 114° |
| Maximum clam opening | – | 38.3 in (972 mm) |
| Moldboard height | – | 36.8 in (934 mm) |
| Raising time to full height | 4.6 sec | 4.6 sec |
| Bucket dumping time | 1.1 sec | 1.1 sec |
| Lowering time: | | |
| Power down | 2.6 sec | 2.6 sec |
| Return-to-dig | 3.6 sec | 3.6 sec |
| Clam: | | |
| Open time | – | 1.0 sec |
| Close time | – | 1.0 sec |

NOTE: Loader dimensions taken with 4WD, 19.5 L x 24.0 rear tires.

DIMENSIONS

| | 2WD with 19.5 L x 24.0 tires | 4WD with 19.5 L x 24.0 tires |
|--------------------------------------|------------------------------|------------------------------|
| M. Overall transport length: | | |
| Long Lip bucket with Quick Coupler | 23 ft 5 in (7.14 m) | 23 ft 4 in (7.10 m) |
| 4 IN 1® bucket with Quick Coupler | 23 ft 3 in (7.07 m) | 23 ft 1 in (7.04 m) |
| Long Lip bucket with Straight Links | 23 ft 6 in (7.15 m) | 23 ft 4 in (7.12 m) |
| 4 IN 1® bucket with Straight Links | 23 ft 3 in (7.09 m) | 23 ft 2 in (7.06 m) |
| Overall transport width – rear tires | 6 ft 10 in (2.07 m) | 6 ft 10 in (2.07 m) |
| Height: | | |
| To top of canopy | 8 ft 9 in (2.66 m) | 8 ft 9 in (2.66 m) |
| To top of cab | 8 ft 11 in (2.72 m) | 8 ft 11 in (2.72 m) |
| To top of exhaust stack | 8 ft 7 in (2.62 m) | 8 ft 7 in (2.61 m) |
| N. Transport | 10 ft 10 in (3.30 m) | 11 ft 1 in (3.37 m) |
| Ground clearance at backhoe frame | 15.0 in (380 mm) | 15.0 in (380 mm) |
| Angle of departure | 15.3° | 19.0° |
| Front wheel tread: | | |
| 11.0 L x 16.0 | 67.5 in (1.71 m) | 67.5 in (1.71 m) |
| 12.0 L x 16.5 | 67.7 in (1.72 m) | 67.7 in (1.72 m) |
| Rear wheel tread: | | |
| 17.5 L x 24.0 | 63.1 in (1.60 m) | 63.1 in (1.60 m) |
| 19.5 L x 24.0 | 61.2 in (1.55 m) | 61.2 in (1.55 m) |
| Width over tires: | | |
| 11.0 L x 16.0 | 79.3 in (2.01 m) | 79.3 in (2.01 m) |
| 12.0 L x 16.5 | 81.1 in (2.06 m) | 81.1 in (2.06 m) |
| 17.5 L x 24.0 | 81.7 in (2.07 m) | 81.7 in (2.07 m) |
| 19.5 L x 24.0 | 81.4 in (2.07 m) | 81.4 in (2.07 m) |
| O. Wheelbase | 84.0 in (2.13 m) | 84.5 in (2.15 m) |

CYLINDERS

| | Bore Diameter | Rod Diameter | Stroke | Closed Length |
|------------------|--------------------|-------------------|-----------------------|-----------------------|
| Loader: | | | | |
| Lift – 2 | 3.25 in (82.6 mm) | 1.75 in (44.5 mm) | 28.86 in (733.0 mm) | 41.81 in (1 062.0 mm) |
| Dump – 2 | 3.00 in (76.2 mm) | 1.50 in (38.1 mm) | 20.33 in (516.5 mm) | 30.31 in (769.9 mm) |
| 4 IN 1® clam – 2 | 3.00 in (76.2 mm) | 1.75 in (44.5 mm) | 9.08 in (230.6 mm) | 19.62 in (498.3 mm) |
| Backhoe: | | | | |
| Boom | 4.50 in (114.3 mm) | 2.25 in (57.2 mm) | 38.22 in (971.5 mm) | 52.82 in (1 341.6 mm) |
| Dipperstick | 4.25 in (108.0 mm) | 2.25 in (57.2 mm) | 25.14 in (628.5 mm) | 39.65 in (1 007.0 mm) |
| Bucket | 3.25 in (82.6 mm) | 2.25 in (57.2 mm) | 35.35 in (897.9 mm) | 48.17 in (1 223.6 mm) |
| Extendahoe® | 3.00 in (76.2 mm) | 1.75 in (44.5 mm) | 42.05 in (1 068.0 mm) | 56.22 in (1 428.0 mm) |
| Swing – 2 | 3.75 in (95.3 mm) | 2.00 in (50.8 mm) | 11.50 in (292.0 mm) | 24.44 in (620.8 mm) |
| Stabilizer – 2 | 4.25 in (108.0 mm) | 2.25 in (57.2 mm) | 21.37 in (542.9 mm) | 33.87 in (860.2 mm) |

AXLE RATINGS

| | Front – 2WD | Rear | Front – 4WD |
|--------------------------|------------------------------|-----------------------|------------------------------|
| Maximum static | 70,821 lb (32 124 kg) | 90,145 lb (40 889 kg) | 64,613 lb (29 308 kg) |
| Dynamic operating | 44,261 lb (20 076 kg) | 56,200 lb (25 492 kg) | 39,328 lb (17 839 kg) |
| Static operating | 17,704 lb (8 030 kg) | 22,480 lb (10 197 kg) | 15,732 lb (7 136 kg) |
| Oscillation – front axle | 22° total – 11° side to side | – | 22° total – 11° side to side |

BACKHOE LIFT CAPACITIES

| Standard Backhoe | | Extendahoe® | |
|---------------------|--------------------------|---------------------------------------|--------------------------------------|
| Boom Lift | Lift Capacity lb (kg) | Retracted Lift Capacity lb (kg) | Extended Lift Capacity lb (kg) |
| +16 ft (4.87 m) | — | — | 1,693 (768) |
| +14 ft (4.27 m) | 2,472 (1 121) | 2,271 (1 030) | 1,979 (897) |
| +12 ft (3.66 m) | 2,857 (1 296) | 2,644 (1 199) | 2,124 (964) |
| +10 ft (3.05 m) | 2,966 (1 345) | 2,748 (1 246) | 2,172 (985) |
| +8 ft (2.44 m) | 2,983 (1 353) | 2,761 (1 252) | 2,169 (984) |
| +6 ft (1.83 m) | 2,963 (1 344) | 2,739 (1 242) | 2,173 (985) |
| +4 ft (1.22 m) | 2,929 (1 329) | 2,701 (1 225) | 2,165 (982) |
| +2 ft (0.61 m) | 2,892 (1 312) | 2,662 (1 207) | 2,153 (977) |
| Ground Level | 2,858 (1 297) | 2,625 (1 191) | 2,153 (977) |
| -2 ft (0.61 m) | 2,834 (1 285) | 2,598 (1 178) | 2,145 (973) |
| -4 ft (1.22 m) | 2,827 (1 282) | 2,588 (1 174) | 2,143 (972) |
| -6 ft (1.83 m) | 2,853 (1 294) | 2,609 (1 183) | 2,154 (977) |
| -8 ft (2.44 m) | 2,949 (1 338) | 2,698 (1 224) | 2,189 (993) |
| -10 ft (3.05 m) | 3,319 (1 506) | 3,053 (1 385) | 2,270 (1 030) |
| -12 ft (3.66 m) | — | — | 2,429 (1 102) |
| -14 ft (4.27 m) | — | — | 3,115 (1 413) |
| Dipper Lift | | | |
| +14 ft (4.27 m) | — | — | 3,154 (1 431) |
| +12 ft (3.66 m) | 4,343 (1 970) | 4,139 (1 877) | 2,981 (1 352) |
| +10 ft (3.05 m) | 4,027 (1 827) | 3,826 (1 735) | 2,823 (1 281) |
| +8 ft (2.44 m) | 4,112 (1 865) | 3,910 (1 774) | 2,855 (1 295) |
| +6 ft (1.83 m) | 4,563 (2 070) | 4,357 (1 976) | 3,010 (1 365) |
| +4 ft (1.22 m) | 5,398 (2 449) | 5,177 (2 348) | 2,948 (1 337) |
| +2 ft (0.61 m) | — | — | 3,486 (1 581) |

BACKHOE OPERATIONAL DATA

| Standard Backhoe | | Extendahoe® | |
|----------------------------------|----------------------|----------------------|----------------------|
| | | Retracted | Extended |
| Digging depth: | | | |
| Maximum | 14 ft 9 in (4.50 m) | 14 ft 9 in (4.50 m) | 18 ft 3 in (5.55 m) |
| 2 ft (610 mm) flat bottom | 14 ft 8 in (4.46 m) | 14 ft 8 in (4.46 m) | 18 ft 1 in (5.52 m) |
| 8 ft (2.44 m) flat bottom | 13 ft 8 in (4.16 m) | 13 ft 8 in (4.16 m) | 17 ft 4 in (5.29 m) |
| Overall reach from: | | | |
| Rear axle centerline | 21 ft 11 in (6.68 m) | 21 ft 11 in (6.68 m) | 25 ft 4 in (7.72 m) |
| Swing pivot | 18 ft 4 in (5.57 m) | 18 ft 4 in (5.57 m) | 21 ft 8 in (6.60 m) |
| Loading height | 11 ft 9 in (3.59 m) | 11 ft 9 in (3.59 m) | 14 ft 1 in (4.30 m) |
| Loading reach – dipper retracted | 6 ft 9 in (2.04 m) | 6 ft 9 in (2.04 m) | 9 ft 4 in (2.84 m) |
| Swing arc | 180° | 180° | 180° |
| Bucket rotation: | | | |
| Straight links | 175.6° | 175.6° | 175.6° |
| Mechanical coupler | 198.0° | 198.0° | 198.0° |
| Stabilizer spread – centers: | | | |
| Flip pad | 9 ft 5 in (2.87 m) | 9 ft 5 in (2.87 m) | 9 ft 3 in (2.81 m) |
| Cast Pad | 9 ft 9 in (2.97 m) | 9 ft 9 in (2.97 m) | 9 ft 7 in (2.92 m) |
| Digging force: | | | |
| Bucket cylinder | 11,517 lb (51 228 N) | 11,517 lb (51 228 N) | 11,517 lb (51 228 N) |
| Dipper cylinder | 6,710 lb (29 484 N) | 6,710 lb (29 484 N) | 4,887 lb (21 738 N) |
| Leveling angle: | | | |
| Flip pad | 12.8° | 12.8° | 12.8° |
| Cast pad | 13.8° | 13.8° | 13.8° |

STANDARD EQUIPMENT

OPERATOR ENVIRONMENT

See page 1

ENGINE

FPT F58FL413C diesel
Cooled EGR
Selective Catalytic Reduction – SCR
Full flow engine oil filter
Air cleaner – replaceable dry type
with radial seal
Aspirated air cleaner
Radiator with de-aeration bottle
Antifreeze to -34° F (-37° C)
Throttles, both rotary hand and foot
Self adjusting belt

DRIVETRAIN

Front axle, as selected:
2WD heavy-duty front axle with
11.0 L x 16.0 tires
4WD heavy-duty mechanically driven front
axle, with 12.0 L x 16.5 tires
Rear axle:
2/4WD heavy-duty outboard planetary drive,
with 17.5 L x 24.0 tires
4F-4R Power Shuttle
Synchromesh transmission
Torque converter – 11.8 in (300 mm)
On-the-go electric 4WD control
Electric F/R shuttle control
Electric differential lock control,
with push-button activation on
the loader control lever
Park brake, spring-applied, hydraulic
release - SAHR

HYDRAULICS

Gear pump:
28.5 gal/min @ 3,350 psi
(107.9 L/min @ 231 bar)
Heavy-duty hydraulic oil cooler
7-micron, spin on oil filter

LOADER

See page 2

BACKHOE

See page 2

OTHER

Forward tilt engine hood
Replaceable, molded front bumpers
Front/Rear tie downs
Reflective logos
Lights – cab and canopy:
2 front driving
2 rear tail/stop
2 front flashers/turn
2 rear flashers/turn
Lights – cab only:
Adjustable halogen work lights – 55 W:
2 front
2 side – left and right
4 rear
Lights – canopy only:
Adjustable halogen work lights – 55 W:
2 side – left and right
2 rear

TELEMATICS

CASE SiteWatch™ Telematics – includes
hardware and a 3-yr Advanced
data subscription

OPTIONAL EQUIPMENT

OPERATOR ENVIRONMENT

Speed Selectable Auto Ride Control – 4WD models
Standard Ride Control – 2WD models
Comfort Steering with momentary latching switch, two-speed steering pump and 3rd/4th gear cutout
ROPS/FOPS certified protective cab with rear wipers and floor mat
Cab Convenience Package containing pull-down sun visor, window washer – front and rear, left-hand storage tray, deluxe interior package, tilt steering column, Sound Reduction Package for cab models – levels reduced to 72 dB (A), right-hand threshold storage box, viscous fan
Air-conditioning for cab models
Mechanical suspension seat with flip-up armrests, 180° swivel, heated cloth or vinyl, adjustable seat and weight, backrest angle, lumbar and cushion angle
Air Ride suspension seat with flip-up armrests, 180° swivel, heated, electric height adjustment, adjustable backrest and lumbar support – cab units cloth, canopy units vinyl
Pull-down sun visor for canopy models
Radio, AM/FM Stereo/WB, MP3 auxiliary input – cab models
3 in (75 mm) seat belt for mechanical and air-suspension seat

ENGINE

Cold Weather Starting Aid with dual 12 Volt batteries and glow plugs
Block heater

DRIVETRAIN

Powershift S-Type transmission, 4F-3R fully synchronized, electronic transmission controller and kick down in loader control lever – 2WD or 4WD
Heavy-duty outboard planetary drive without 19.5 L x 24.0 tires

LOADER

Auxiliary hydraulics for loader-mounted equipment with thumb-operated proportional control
Hydraulic front quick coupler
Loader linkage without loader bucket
Tool portfolio of additional attachments
Buckets – see page 2

BACKHOE

Auxiliary backhoe unidirectional hydraulics
Auxiliary backhoe combo hydraulics:
Hand lever operated for bidirectional manual controls
Button operated for pilot controls, includes unidirectional and bidirectional
Auxiliary hydraulics with flow from 0 to 28 gal/min (0 to 106 L/min)
Extendahoe®
Two-lever controls - backhoe or Extendahoe®

Pilot operated control system:
Fingertip proportional Electro-Hydraulic stabilizer controls
Thumb-operated proportional Electro-Hydraulic Extendahoe® control
Thumb-operated horn button
Thumb-operated auxiliary hydraulic control
Infinitely adjustable towers
In-cab switchable “excavator to backhoe” control pattern change
Flip over stabilizer pads
Cemetery/Street pads
Case mechanical quick coupler
Universal coupler – CAT/Deere compatible
Buckets – see page 2

OTHER

Front:
11.0 L x 16.0 10-ply or 12.0 L x 16.5 8-ply
Rear:
17.5 L x 24.0 10-ply or 19.5 L x 24.0 10-ply
Special paint
Canopy lights – Additional 2 front and 2 rear halogen lights – 55 W
Tool box – bolt-on, step-mounted
Front counterweights:
700 lb and 1,100 lb (318 kg and 500 kg)
Rotating beacon
Master disconnect switch and remote jump-start terminals
Eco-Mode – Detent on backhoe hand throttle, push button switch on desk

CaseCE.com

©2017 CNH Industrial America LLC. All rights reserved. CASE is a trademark registered in the United States and many other countries, owned by or licensed to CNH Industrial N.V., its subsidiaries or affiliates. CNH Industrial Capital is a trademark in the United States and many other countries, owned by or licensed to CNH Industrial N.V., its subsidiaries or affiliates. Printed in U.S.A. Contains 10% post-consumer fiber.

IMPORTANT: CASE Construction Equipment Inc. reserves the right to change these specifications without notice and without incurring any obligation relating to such change. Availability of some models and equipment builds vary according to the country in which the equipment is used. The illustrations and text may include optional equipment and accessories and may not include all standard equipment. Your CASE dealer/distributor will be able to give you details of the products and their specifications available in your area.



CASE Construction Equipment is biodiesel-friendly. NOTE: All engines meet current EPA emissions regulations. All specifications are stated in accordance with SAE Standards or Recommended Practices, where applicable.



Always read the Operator's Manual before operating any equipment. Inspect equipment before using it, and be sure it is operating properly. Follow the product safety signs and use any safety features provided.

Form No. CCE201702580N
Replaces Form No. CCE201603580NT4